

FLAT BED LATHE **CNC** SERIES

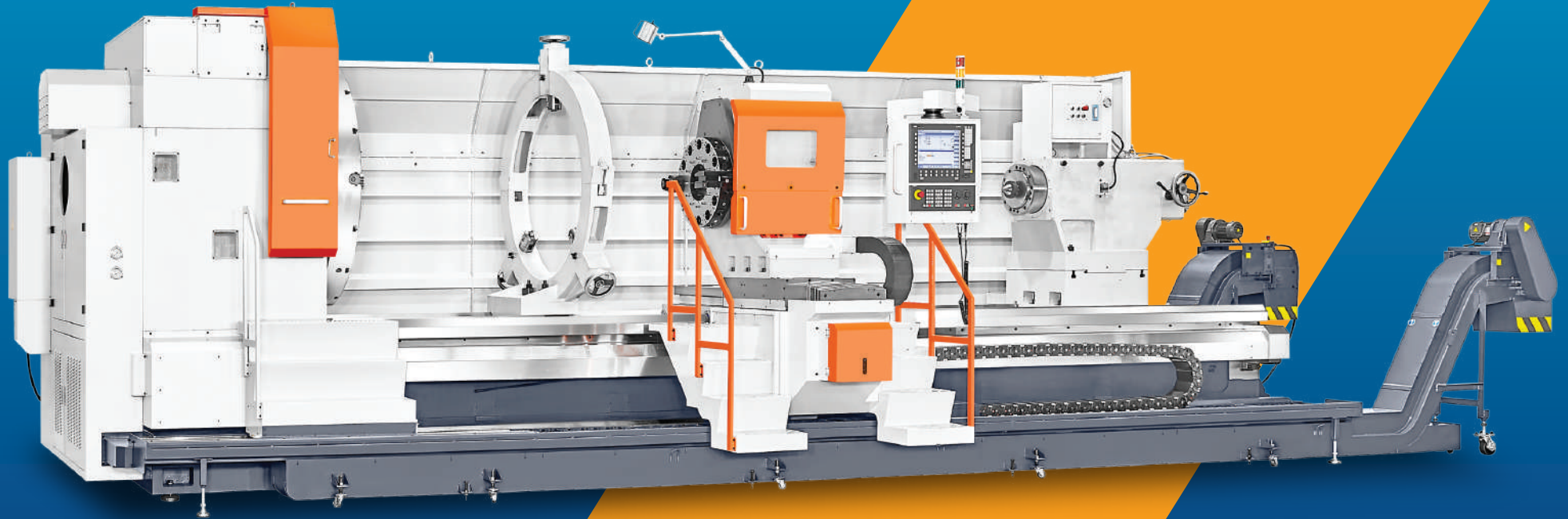

MYDAY
MACHINERY INC.

BUILDING
GREAT MACHINES
MAKES...

COMPANY PROFILE

WHY IS MYDAY?

The company MYDAY was named and founded by Mr. SHU-HUANG CHEN. The idea behind MYDAY came from a vision of success linked machines that bring great success to customers. The vision behind MYDAY is that it **"BRIGHTENS YOUR DAY."**

This family business, founded in 1980, is now in its 2nd generation, with Mr. KO-MIN CHEN having worked alongside Mr. SHU-HUANG CHEN since 2011. Having become president in 2019, Mr. KO-MIN CHEN has 10 years work experience with machine tools, equipping a variety of knowledge in engineering solutions and analysis. Our new president is ready to lead MYDAY into a new era.

MYDAY is located in Taichung, the focal city of the machine tooling industry with strong linkage to supply chains makes acceleration in the production process accessible and achievable. Measuring at 6,000-square-meters the company's facility offers extensive use of the latest lean manufacturing methods.

Today, MYDAY produces oil country lathe, CNC heavy duty lathe, screw milling machine and specialized lathe. MYDAY remains a reliable project solution provider for current and future solutions.

CORE FOCUS OF MYDAY



R&D

- A team with solid expertise supports and assists our customers to carry out customized design evaluations.
- In close cooperation with national research institutions we gain up-to-date knowledge and information to evaluate performance levels and improve them.

QC

- Test Lab equipped with advanced instruments to control quality of materials.
- QC Methods: 7 basic quality tools to ensure optimum output.

SERVICE

- ROMOTE Service: quick service support by well-trained MYDAY sales team.
- IN-TIME Service: providing service support by our dealers worldwide.

HR

- Design different training programs annually to enhance staff expertise.
- Considerate care for employee benefits and their working environment.

MYDAY



*MIGHT NOT BE THE BEST,
BUT WE ARE TRYING OUR BEST TO
BE THE BEST CHOICE.*

CNC FLAT BED LATHE SERIES

INTRODUCTION OF SERIES NAME			
	P / Precision	O / Oil Country	G / Multi-Guideway
M / Conventional	MPA, MPB	MOC, MOH	MGF, MGX
S / CNC	SPA, SPB	SOC, SOH	SGE, SGF, SGX

INTRODUCTION OF MODEL NAME				
MODEL NAME	SPA	XX	OOO	□
MEANING	SERIES NAME	SWING OVER BED	DISTANCE BETWEEN CENTERS <small>*per 100mm</small>	SPINDLE BORE
EXAMPLE	SPA	770	15	3

// MODEL SERIES

PRECISION SERIES (CNC)



CNC PRECISION LATHE - 16" BED
SPA600 / SPA670 / SPA770

SPA



CNC PRECISION LATHE - 18" BED
SPB670 / SPB770 / SPB840

SPB

OIL COUNTRY SERIES (CNC)



CNC OIL COUNTRY LATHE - 22" BED
SOC960 / SOC1060

SOC



CNC HEAVY DUTY OIL COUNTRY LATHE - 32" BED
SOH1200 / SOH1400 / SOH1600

SOH

MULTI-GUIDEWAY SERIES (CNC)



CNC GIANT FOUR GUIDEWAY LATHE - 52" BED
SGF1800 / SGF2000 / SGF2250 / SGF2500

SGF



CNC FOUR GUIDEWAY LATHE - 53" BED
SGE1500S / SGE1500

SGE



CNC CUSTOMIZED GIANT LATHE - 72" BED
SGX2600 / SGX3100 / SGX3600

SGX

TEST REPORT

// ACCESSORY REPORT

GSA 旭慶國際精機股份有限公司
GSA TECHNOLOGY CO., LTD.

CNC TOOL TURRET INSPECTION RECORD LIST

MODEL: CLS-580L-8T SKU NO: 201501470001

INSPECTION DATE: 2022.11 CUSTOMER:

INSPECTOR: DC24V PNP OUTSIDE VALUE VOLTAGE: ACTIVE

No.	Inspection Item	Description	Allowance	Measure
1	Center height	Mark actual value after seal	mm: 0.00±0.01	
2	Surface flatness	100% surface	0.02mm	0.02mm
3	Perpendicularity of end surface	100% surface	0.02mm	0.02mm
4	Perpendicularity of disc surface	100% surface	0.02mm	0.02mm
5	Roundness of disc surface	100% surface	0.02mm	0.02mm
6	Max. distance of part holder surface	100% surface	0.02mm	0.02mm

PG-001828-A

Turret Inspection Report

LEADERTEK PRECISION INC.
INSPECTION CERTIFICATE

NO. NUMBER: 202403-01

INSPECTOR: MICHAEL ZHOU CHRISTER ZHANG

DATE: 2024/03/12

ITEM: BALL SCREW

DIAMETRAL	STANDARD	ACTUAL	PERMISSIBLE	STANDARD	ACTUAL
T1	0.010	0.010	±	0.010	0.010
T2	0.011	0.012	±	0.010	0.012
T3	0.006	0.007	±	0.005	0.007
T4	0.010	0.009	±	0.010	0.009
T5	0.009	0.008	±	0.010	0.008
T6	0.009	0.008	±	0.010	0.008

INSPECTED BY: MICHAEL ZHOU CHRISTER ZHANG ALLOWABLE: ACTUAL:

REPRESENTATIVE ACCUMULATED LEAD: T.S. (UM) 0.02 0.02

LEAD VARIATION WITHIN EFFECTIVE STROKE: 0.2 (UM) 0.2 0.2

PRELOAD TORQUE (OUTER) WITHIN: Tg (kgf-cm) 1.0F 1.2

ACCURACY GRADE FOR RELEASED ORDER: C3 C3

Ball Screw Inspection Report

// BED REPORT

YING CHEN FURNACE INDUSTRY CO., LTD.
CAST IRON TEST REPORT

DATE: 2024.11.29

ITEM: CAST IRON

ITEM	STANDARD	ACTUAL	PERMISSIBLE	STANDARD	ACTUAL
1	0.10	0.10	±	0.10	0.10
2	0.15	0.15	±	0.15	0.15
3	0.10	0.10	±	0.10	0.10
4	0.10	0.10	±	0.10	0.10
5	0.10	0.10	±	0.10	0.10

INSPECTED BY: MICHAEL ZHOU CHRISTER ZHANG ALLOWABLE: ACTUAL:

Cast Iron Test Report

// SAFETY CERTIFICATION

SGS Report No.: R020190050 Page 1 of 10

TEST REPORT
Safety of Machinery - Electrical Equipment of Machines

Client Ref. No.:

Product Name:

Manufacturer:

Model No.:

Serial No.:

Inspector:

Reviewed by:

Issue Date:

Expiry Date:

Signature:

SGS Report

// ACCURACY REPORT: LASER REPORT

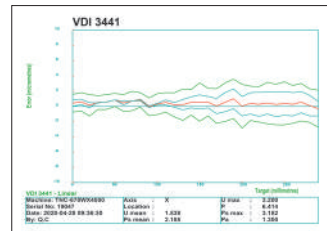

19047-X Axis

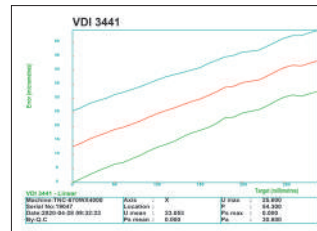

19047-X0 Axis

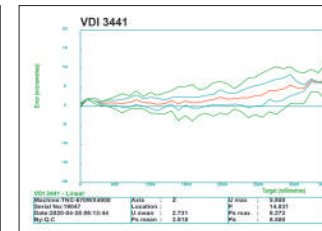

19047-Z Axis

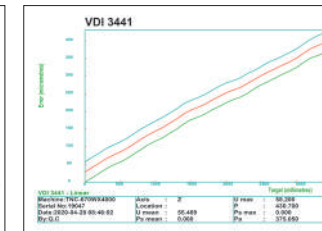

19047-Z0 Axis

BED CASTING



▶ 18" Bed Casting



▶ 22" Bed Casting



▶ 52" Bed Casting

QUALITY CONTROL

We focus on most important aspects in guaranteeing the reliability followed by rigorous QC process in all key components. Assurance reports such as casting testing report for bed, headstock, tailstock provided by our suppliers, plus internal IQC and FQC to make sure MYDAY machines with high accuracy performance.

CNC PRECISION LATHE - 16" BED



CNC Heavy Duty Precision Lathe is a very popular product line in metal industry.

The spindle motor power in the series is transmitted to the spindle through pulley, belt and 4-step gear sets. It could perform heavy duty machining with high speed and high rigidity.

▶ SPA770



// LOADING CAPACITY

Between Spindle Center & Tailstock Center	Between Spindle Center & Tailstock Center & One Steady Rest	Between Spindle Center & Tailstock Center & Two Steady Rest	Only One Chuck
2500 KG / 5500 LB	3500 KG / 7700 LB	4500 KG / 9900 LB	250 KG / 550 LB

// SPECIFICATION Below information is for reference only.

CNC Precision Series		Unit	SPA600	SPA670	SPA770
Machining Area	Center Height	mm	300	335	385
	Swing over Bed	mm	600	670	770
	Swing over Cross Slide	mm	310	380	480
	Width of Bed	mm	400		
	Distance Between Centers	mm	1500 ~ 3000		
Headstock	Spindle Bore	mm	80 (3") 104 (4")		
	Spindle Nose		A2-8, D1-8 A2-11		
	Spindle Speeds	rpm	16 - 1500 13 - 1200		
	Number of Spindle Speeds		4 4		
Carriage	Rapid Travel Speed (Z / X)	m/min	5 / 5		
	Z-axis Travel, Max	mm	1300 ~ 2800		
	X-axis Travel, Max	mm	350		
	Z-axis Ball Screw	mm	Ø50		
	X-axis Ball Screw	mm	Ø32		
Tailstock	Quill Diameter	mm	Ø95		
	Quill Taper		MT5		
	Quill Travel	mm	230		
Drives	CNC System		FAGOR 8055i	FANUC 0i-TF	SIEMENS 828D
	Spindle Motor	kw	15	15	15
	Z-axis Servo Motor	kw	2.3	2.5	2.3
	X-axis Servo Motor	kw	1.4	1.4	1.48

// OPTIONAL ACCESSORY FOR SPA To check the accessory pictures, turn to page 21 and 22.

No.	Optional Accessory	Specification	SPA600/B3	SPA600/B4	SPA670/B3	SPA670/B4	SPA770/B3	SPA770/B4
01	3-Jaw Scroll Chuck	Diameter (inch)	10" / 12" / 16"	12" / 16"	10" / 12" / 16"	12" / 16"	10" / 12" / 16"	12" / 16"
02	4-Jaw Chuck	Diameter (inch)	16" / 20"	20"	16" / 20"	20"	16" / 20"	20"
13	Hydraulic 4-Way Toolpost (Taiwan)	Tool Size	NO	NO	□32	□32	□40	□40
14	Hydraulic 8-Station Turret (Taiwan)	Tool Size	□25	□25	□25	□25	□25	□25
05	Follow Rest	Ø30 - 150	Y	Y	Y	Y	Y	Y
06	Steady Rest	Range (mm)	50 - 380	50 - 380	50 - 380 300 - 530	50 - 380 300 - 530	50 - 380 300 - 530	50 - 380 300 - 530
10	Boring Device	≤Ø120 mm	Y	Y	Y	Y	Y	Y
15	Enclosed Rear Chuck Guard		NO	Y	NO	Y	NO	Y
16	Fully Enclosed Splash Guard		Y	Y	Y	Y	Y	Y
17	Chip Conveyor with Oil Skimmer		Y	Y	Y	Y	Y	Y
12	Heavy Duty Live Center	MT5	Y	Y	Y	Y	Y	Y

CNC PRECISION LATHE - 18" BED



CNC Heavy Duty Precision Lathe is a very popular product line in metal industry.

The spindle motor power in the series is transmitted to the spindle through pulley, belt and 4-step gear sets. It could perform heavy duty machining with high speed and high rigidity.

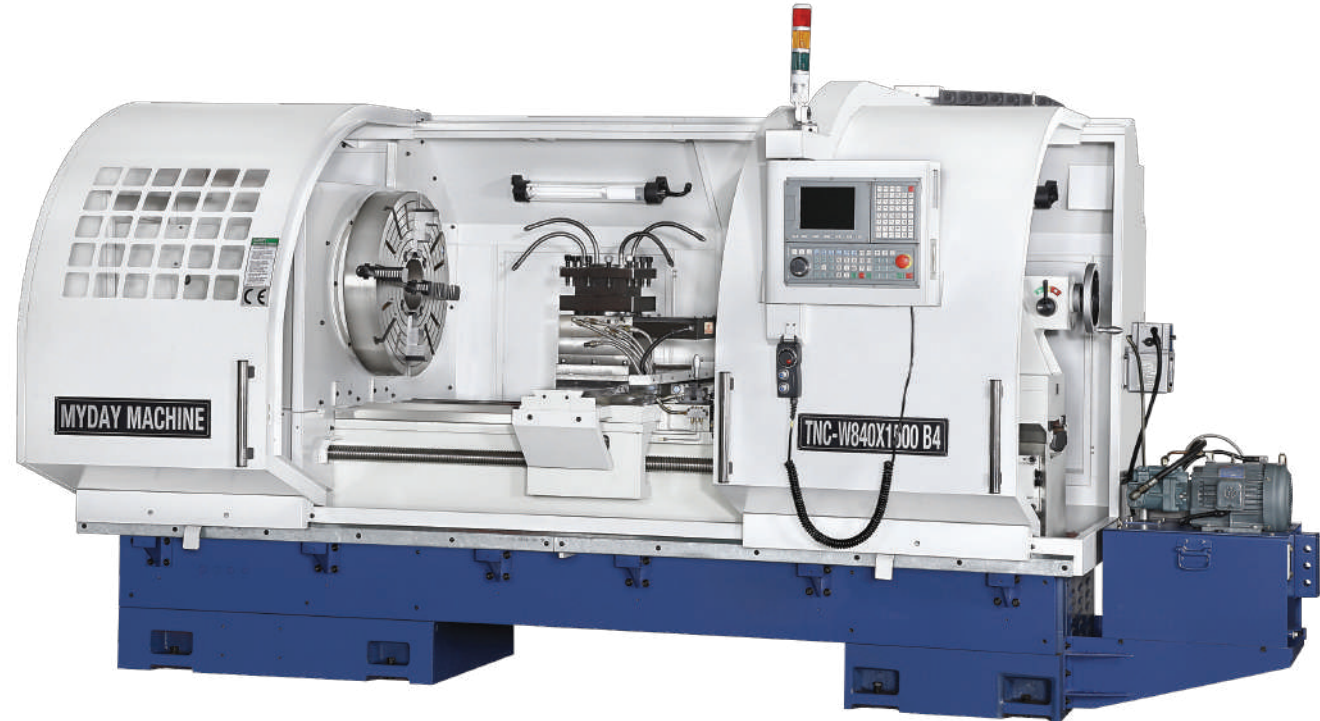

▶ **SPB840**

// LOADING CAPACITY

Between Spindle Center & Tailstock Center	Between Spindle Center & Tailstock Center & One Steady Rest	Between Spindle Center & Tailstock Center & Two Steady Rest	Only One Chuck
4000 KG / 8800 LB	5000 KG / 11000 LB	6000 KG / 13200 LB	500 KG / 1100 LB

// **SPECIFICATION** Below information is for reference only.

CNC Precision Series		Unit	SPB670	SPB770	SPB840
Machining Area	Center Height	mm	335	385	420
	Swing over Bed	mm	670	770	840
	Swing over Cross Slide	mm	380	480	550
	Width of Bed	mm	460		
	Distance Between Centers	mm	1500 ~ 5000		
Headstock	Spindle Bore	mm	104 (4") 156 (6") 230 (9")		
	Spindle Nose		A2-11 A2-11 A2-15		
	Spindle Speeds	rpm	13 - 1200 11 - 800 4 - 600		
	Number of Spindle Speeds		4 4 4		
Carriage	Rapid Travel Speed (Z / X)	m/min	5 / 5		
	Z-axis Travel, Max	mm	1300 ~ 4800		
	X-axis Travel, Max	mm	410		
	Z-axis Ball Screw	mm	Ø50		
	X-axis Ball Screw	mm	Ø32		
Tailstock	Quill Diameter	mm	Ø105		
	Quill Taper		MT5		
	Quill Travel	mm	230		
Drives	CNC System		FAGOR 8055i	FANUC 0i-TF	SIEMENS 828D
	Spindle Motor	kw	15	15	15
	Z-axis Servo Motor	kw	2.3	2.5	2.3
	X-axis Servo Motor	kw	1.4	1.4	1.48

// **OPTIONAL ACCESSORY FOR SPB** To check the accessory pictures, turn to page 21 and 22.

No.	Optional Accessory	Specification	SPB670/B4 SPB770/B4 SPB840/B4	SPB670/B6 SPB770/B6 SPB840/B6	SPB670/B9 SPB770/B9 SPB840/B9
01	3-Jaw Scroll Chuck	Diameter (inch)	12" / 16"	16" / 20"	25"
02	4-Jaw Chuck	Diameter (inch)	20"	20"	24" / 25"
13	Hydraulic 4-Way Toolpost (Taiwan)	Tool Size	□32	□40	□40
14	Hydraulic 8-Station Turret (Taiwan)	Tool Size	□25	□25	□25
05	Follow Rest	Ø30 - 150	Y	Y	Y
06	Steady Rest	Range (mm)	50 - 380 300 - 530	50 - 380 300 - 530	50 - 380 300 - 530
10	Boring Device	≤Ø120 mm	Y	Y	Y
15	Enclosed Rear Chuck Guard		Y	Y	Y
16	Fully Enclosed Splash Guard		Y	Y	Y
17	Chip Conveyor with Oil Skimmer		Y	Y	Y
12	Heavy Duty Live Center	MT5	Y	Y	Y

CNC OIL COUNTRY LATHE - 22" BED



CNC Oil Country Lathe is a famous product line for oil and gas field services industry and metal industry. The design of machine can be modified either to big bore lathes equipped with double chuck at both sides of headstock, or providing a large swing for big work-pieces.

The machine is generally applied to oil pipes, big steel rollers, large diameter flanges, long shafts of ships etc. In addition, the tailstock of machine can be changed to a rotary quill as an optional for better work-piece clamping.

▶ SOC1060



// LOADING CAPACITY

Between Spindle Center
& Tailstock Center

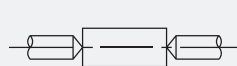

6000 KG / 13200 LB

Between Spindle Center
& Tailstock Center
& One Steady Rest

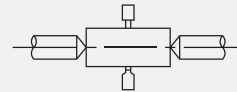

7500 KG / 16500 LB

Between Spindle Center
& Tailstock Center
& Two Steady Rest

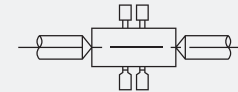

9000 KG / 19800 LB

Only One Chuck

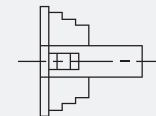

2000 KG / 4400 LB

// **SPECIFICATION** Below information is for reference only.

CNC Oil Country Series		Unit	SOC960			SOC1060			
Machining Area	Center Height	mm	480			530			
	Swing over Bed	mm	960			1060			
	Swing over Cross Slide	mm	530			630			
	Width of Bed	mm	560						
	Distance Between Centers	mm	1500 ~ 6000						
Headstock	Spindle Bore	mm	156 (6")	230 (9")	260 (10")	310 (12")	360 (14")		
	Spindle Nose		A2-11	A2-15	A2-15	A2-20	A2-20		
	Spindle Speeds	rpm	6 - 800	4 - 600	4 - 540	3 - 400	3 - 360		
	Number of Spindle Speeds		4	4	4	3	3		
Carriage	Rapid Travel Speed (Z / X)	m/min	5 / 5						
	Z-axis Travel, Max	mm	1250 ~ 5750						
	X-axis Travel, Max	mm	600						
	Z-axis Ball Screw	mm	Ø63*						
	X-axis Ball Screw	mm	Ø40						
Tailstock	Quill Diameter	mm	Ø140						
	Quill Taper		MT6						
	Quill Travel	mm	300						
Drives	CNC System		FAGOR 8055i			FANUC 0i-TF		SIEMENS 828D	
	Spindle Motor	kw	22		22		22		
	Z-axis Servo Motor	kw	3.8		4.0		4.85		
	X-axis Servo Motor	kw	3.5		3.0		3.3		

* Z-axis transmission is by racks and dual pinions if DBC ≥ 6m

// **OPTIONAL ACCESSORY FOR SOC** To check the accessory pictures, turn to page 21 and 22.

No.	Optional Accessory	Specification	SOC960	SOC1060	SOC960	SOC1060	SOC1060	SOC1060	SOC1060
			/B6	/B6	/B9	/B9	/B10	/B10	/B14
01	3-Jaw Scroll Chuck	Diameter (inch)	16" / 20"	16" / 20"	25"	25"	25"	25"	31.5"
03	4-Jaw Chuck	Diameter (inch)	20" / 24"	20" / 24"	24" / 26"	24" / 26"	26"	28"	28"
13	Hydraulic 4-Way Toolpost (Taiwan)	□50	Y	Y	Y	Y	Y	Y	Y
14	Hydraulic 8-Station Turret (Taiwan)	□32	Y	Y	Y	Y	Y	Y	Y
05	Follow Rest	Ø35 - 170	Y	Y	Y	Y	Y	Y	Y
07	Steady Rest	Range (mm)	150 - 380	150 - 380	150 - 380	150 - 380	150 - 380	150 - 380	150 - 380
			300 - 530	300 - 530	300 - 530	300 - 530	300 - 530	300 - 530	300 - 530
			500 - 780	500 - 780	500 - 780	500 - 780	500 - 780	500 - 780	500 - 780
10	Boring Device	Ø150; Ø200	Y	Y	Y	Y	Y	Y	Y
15	Enclosed Rear Chuck Guard		Y	Y	Y	Y	Y	Y	Y
16	Fully Enclosed Splash Guard		Y	Y	Y	Y	Y	Y	Y
12	Live Center	MT6	Y	Y	Y	Y	Y	Y	Y

CNC HEAVY DUTY OIL COUNTRY LATHE - 32" BED



CNC Oil Country Lathe is a famous product line for oil and gas field services industry and metal industry. The design of machine can be modified either to big bore lathes equipped with double chuck at both sides of headstock, or providing a large swing for big work-pieces.

The machine is generally applied to oil pipes, big steel rollers, large diameter flanges, long shafts of ships etc. In addition, the tailstock of machine can be changed to a rotary quill as an optional for better work-piece clamping.

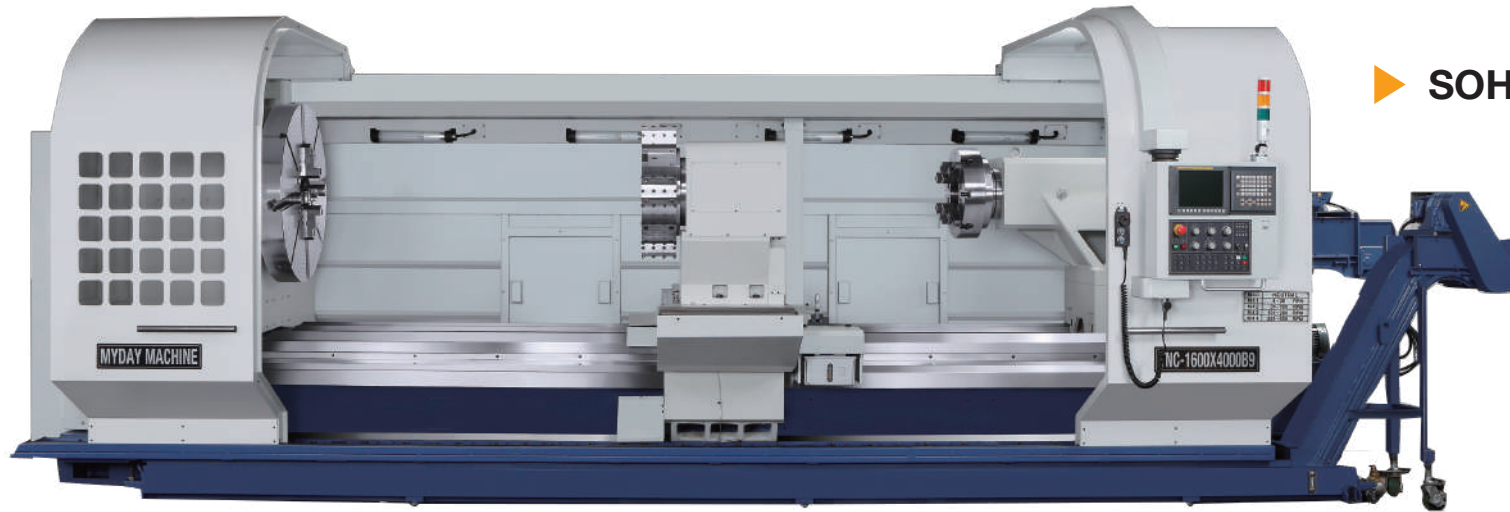

▶ **SOH1600**

// LOADING CAPACITY

A. Spindle Bore $\phi 230$, Tailstock Quill $\phi 200$

B. Spindle Bore $\phi 230$, Tailstock Quill $\phi 290$ (opt.)

C. Spindle Bore $\phi 156 / \phi 260 / \phi 310 / \phi 360 / \phi 410 / \phi 535$,

Tailstock Quill $\phi 200 / \phi 290$

	Between Spindle Center & Tailstock Center	Between Spindle Center & Tailstock Center & One Steady Rest	Between Spindle Center & Tailstock Center & Two Steady Rest	Only One Chuck
A	10000 KG / 22000 LB	12000 KG / 26400 LB	14000 KG / 30800 LB	4000 KG / 8800 LB
B	15000 KG / 33000 LB	17000 KG / 37400 LB	19000 KG / 41800 LB	4000 KG / 8800 LB
C	10000 KG / 22000 LB	12000 KG / 26400 LB	14000 KG / 30800 LB	4000 KG / 8800 LB

// SPECIFICATION Below information is for reference only.

CNC Oil Country Series		Unit	SOH1200		SOH1400		SOH1600		
Machining Area	Center Height	mm	600		700		800		
	Swing over Bed	mm	1190		1385		1580		
	Swing over Cross Slide	mm	740		940		1140		
	Width of Bed	mm	800						
	Distance Between Centers	mm	2000 ~ 10000						
Headstock	Spindle Bore	mm	156 (6")	230 (9")	260 (10")	310 (12")	360 (14")	410 (16")	535 (21")
	Spindle Nose		A2-15	A2-15	A2-15	A2-20	A2-20	A2-28	A2-28
	Spindle Speeds	rpm	6 - 800	4 - 600	4 - 540	3 - 400	3 - 360	2 - 300	2 - 300
	Number of Spindle Speeds		4	4	4	4	4	4	4
Carriage	Rapid Travel Speed (Z / X)	m/min	5 / 5						
	Z-axis Travel, Max	mm	1750 ~ 9750						
	X-axis Travel, Max	mm	800						
	Z-axis Ball Screw	mm	Ø80*						
	X-axis Ball Screw	mm	Ø50						
Tailstock	Quill Diameter	mm	Ø200						
	Quill Taper		MT7						
	Quill Travel	mm	300						
Drives	CNC System		FAGOR 8055i		FANUC 0i-TF		SIEMENS 828D		
	Spindle Motor	kw	22		22		22		
	Z-axis Servo Motor	kw	3.8		4.0		5.4		
	X-axis Servo Motor	kw	3.8		4.0		4.85		

* Z-axis transmission is by racks and dual pinions if DBC ≥ 6m

// OPTIONAL ACCESSORY FOR SOH To check the accessory pictures, turn to page 21 and 22.

No.	Optional Accessory	Specification	SOH1200/B6	SOH1200/B9	SOH1200/B10	SOH1200/B12	SOH1200/B14	SOH1200/B16	SOH1200/B21
			SOH1400/B6	SOH1400/B9	SOH1400/B10	SOH1400/B12	SOH1400/B14	SOH1400/B16	SOH1400/B21
			SOH1600/B6	SOH1600/B9	SOH1600/B10	SOH1600/B12	SOH1600/B14	SOH1600/B16	SOH1600/B21
01	3-Jaw Scroll Chuck	Diameter (inch)	25"	25"	25"	25"	31.5"	NO	NO
03	4-Jaw Chuck	Diameter (inch)	26"	26"	26"	28"	28"	32"	36" / 40"
13	Hydraulic 4-Way Toolpost (Taiwan)	□50	Y	Y	Y	Y	Y	Y	Y
14	Hydraulic 8-Station Turret (Taiwan)	□32	Y	Y	Y	Y	Y	Y	Y
05	Follow Rest	Ø40 - 240 mm	Y	Y	Y	Y	Y	Y	Y
07	Steady Rest	Range (mm) *For SOH1400 & SOH1600 only	150 - 430	150 - 430	150 - 430	150 - 430	150 - 430	150 - 430	150 - 430
			350 - 630	350 - 630	350 - 630	350 - 630	350 - 630	350 - 630	350 - 630
			600 - 880	600 - 880	600 - 880	600 - 880	600 - 880	600 - 880	600 - 880
			*800 - 1100	*800 - 1100	*800 - 1100	*800 - 1100	*800 - 1100	*800 - 1100	*800 - 1100
09	Hydraulic Rear Supporting Stand		Y	Y	Y	Y	Y	Y	Y
10	Boring Device	Ø150; Ø200; Ø250	Y	Y	Y	Y	Y	Y	Y
15	Enclosed Rear Chuck Guard		Y	Y	Y	Y	Y	Y	Y
16	Fully Enclosed Splash Guard		Y	Y	Y	Y	Y	Y	Y

CNC GIANT FOUR GUIDEWAY LATHE - 52" BED



CNC Giant Four Guideway Lathe is a special type of flat bed lathe. It has one wide bed and 2 pairs of guide ways. Its tailstock and steady rests are placed on the pair of guide ways at the rear side. Thus, we would build the carriage across the 4 guide ways (called full length cross slide) as standard model; this model could stand for very heavy duty machining and has

full cross slide travel. Besides, we could build its carriage on one pair of guide way at the front side (called half length cross slide). In this option, the carriage wouldn't interfere with steady rests and its tailstock; it's very good at outer diameter machining at one time without removing steady rests.

▶ SGF1800

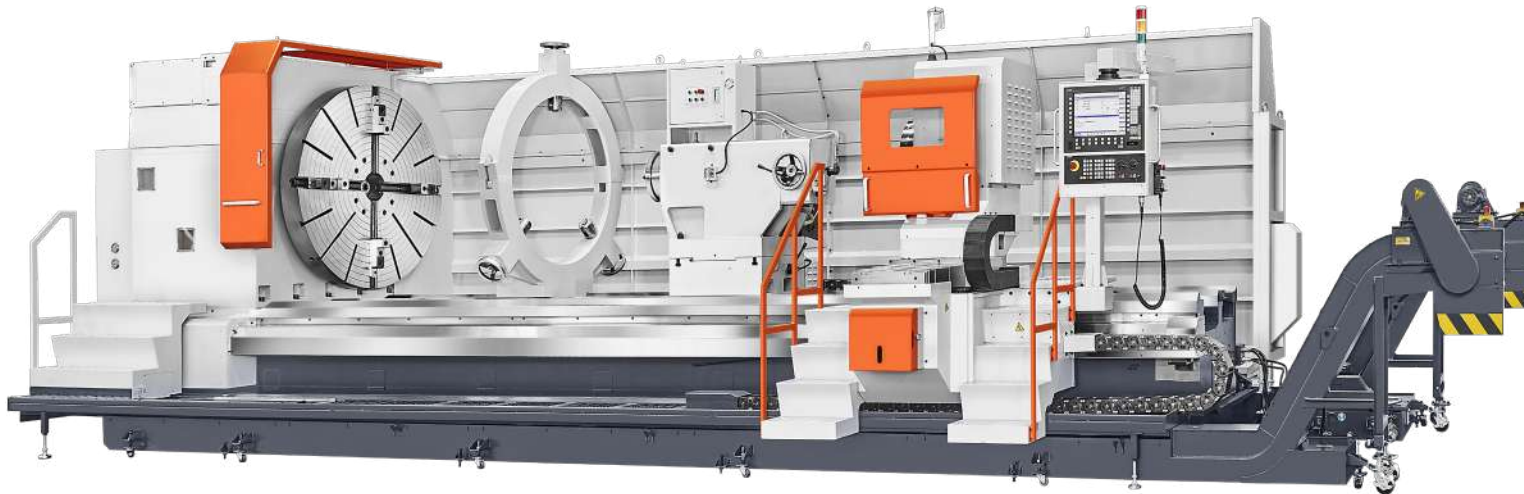

// LOADING CAPACITY

A. Tailstock Quill $\varnothing 290$

B. Tailstock Quill $\varnothing 350$ (opt.) & A2-20 (opt.)

Between Spindle Center & Tailstock Center	Between Spindle Center & Tailstock Center & One Steady Rest	Between Spindle Center & Tailstock Center & Two Steady Rest	Only One Chuck
A 25000 KG / 55000 LB B 33000 KG / 72600 LB	28000 KG / 61600 LB 36000 KG / 79200 LB	31000 KG / 68200 LB 39000 KG / 85800 LB	8000 KG / 17600 LB 8000 KG / 17600 LB

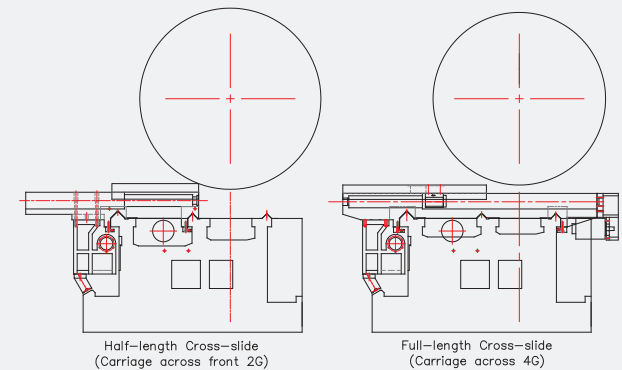

// SPECIFICATION Below information is for reference only.

CNC Multi-Guideway Series		Unit	SGF1800	SGF2000	SGF2250	SGF2500	
Machining Area	Center Height	mm	900	1000	1125	1250	
	Swing over Bed	mm	1800	2000	2250	2500	
	Swing over Cross Slide	mm	1325	1510	1745	1985	
	Width of Bed	mm	1345				
	Distance between Centers	mm	3000 ~ 12000				
Headstock	Spindle Bore	mm	210				
	Spindle Nose		A2-15, A2-20				
	Spindle Speeds	rpm	5 ~ 400				
	Number of Spindle Speeds		4				
Carriage	Rapid Travel Speed (Z / X)	m/min	5 / 5				
	Z-axis Travel, Max	mm	3000 ~ 12000				
	X-axis Travel, Max	mm	720				
	Z-axis Ball Screw (DBC 3 ~ 4 m)	mm	Ø80				
	Z-axis Ball Screw (DBC 5 ~ 6 m)	mm	Ø100*				
Tailstock	X-axis Ball Screw	mm	Ø50				
	Quill Diameter	mm	290				
	Quill Taper		MT7				
	Quill Travel	mm	300				
Drives	CNC System		FAGOR 8055i			FANUC 0i-TF	SIEMENS 828D
	Spindle Motor	kw	Three ▶ Options		51	45	51
	Z-axis Servo Motor	kw			6.3	7.0	8.2
	X-axis Servo Motor	kw			3.8	4.0	5.4

* Z-axis transmission is by racks and dual pinions if DBC ≥ 7m

// OPTIONAL ACCESSORY FOR SGF To check the accessory pictures, turn to page 21 and 22.

No.	Optional Accessory	Specification	SGF1800	SGF2000	SGF2250	SGF2500
03	4-Jaw Chuck	Diameter (inch)	55" / 60" / 63"	63" / 72"	72" / 80"	80"
04	Face Plate	Diameter (inch)	55" / 60" / 63"	60" / 63" / 72"	72" / 80" / 87"	80" / 87"
11	Boring Device	Ø150	Y	Y	Y	Y
08	Steady Rest	Range (mm)	200 - 430	200 - 430	200 - 430	200 - 430
			350 - 580	350 - 580	350 - 580	350 - 580
			570 - 800	570 - 800	570 - 800	570 - 800

CNC FOUR GUIDEWAY LATHE - 53" BED



SGE is a four-guideway lathe series. The tailstock, steady rests and the carriage are designed to sit on two separate pairs of guide ways which effectively limit the interference when the carriage passing by the tailstock. In addition, the carriage is able to move next to both headstock and tailstock so that increase the flexibility in tooling arrangements and clamping. Besides, it is not necessary to remove steady rests or unclamp work-piece

from the chuck amid the process A to process B for without wasting any time. Moreover, the tailstock quill doesn't need to overhang long to approach work-piece which is a plus to maintain the stiffness due to the longer overhang, the weaker quill stiffness. It is optional to equip with a second carriage either to do turning simultaneously, to have a milling station, or to have an individual boring carriage.

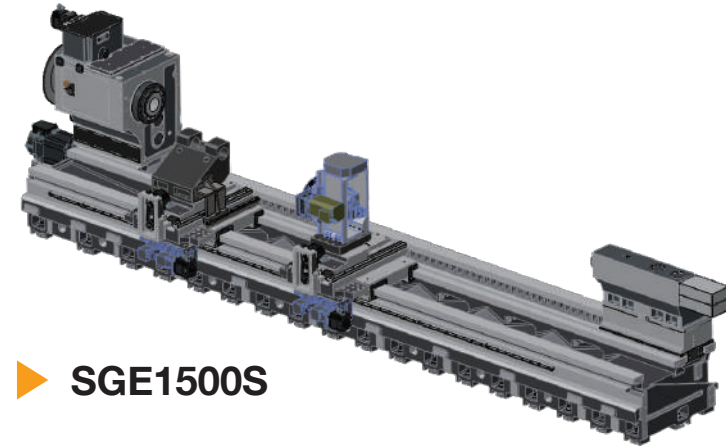

▶ SGE1500S

// **SPECIFICATION** Below information is for reference only.

CNC Multi-Guideway Series		Unit	SGE1500S	SGE1500
Machining Area	Center Height	mm	750	
	Swing over Bed	mm	1500	
	Swing over Cross Slide	mm	1000	
	Width of Bed	mm	1350	
	Distance between Centers	mm	3000 ~ 15000	
Headstock	Spindle Bore	mm	150	156 230
	Spindle Nose		A2-15	A2-11 A2-15
	Spindle Speeds	rpm	1200	600 400
	Number of Spindle Speeds		3	4 4
Carriage	Rapid Travel Speed (Z / X)	m/min	8 / 6	
	Z-axis Travel, Max	mm	3600 ~ 15600	
	X-axis Travel, Max	mm	550	
	Z-axis Ball Screw	mm	Ø80*	
	X-axis Ball Screw	mm	Ø50	
Tailstock	Quill Diameter	mm	220	290
	Quill Taper		MT6	MT7
	Quill Travel	mm	250	
Drives	CNC System		FANUC 0i-TF	SIEMENS 828D
	Spindle Motor	kW	37	37
	Z-axis Servo Motor	kW	4.0	4.85
	X-axis Servo Motor	kW	4.0	4.85

* Z-axis transmission is by racks and dual pinions if DBC ≥ 6m, or if there are two carriages.

CNC CUSTOMIZED GIANT LATHE - 72" BED



▶ SGX2600

SGX is a giant lathe with 72" width of bed designed by totally customized solutions. This model of Machines can be configured to clients requirements. Trying to understand in depth what our customer needs is the most important thing for us to be able to offer the ideal solutions to generate a feasible proposal.

- 2600 ~ 3600mm swings.
- 1830mm bed width with four-guideway bed structure for high stiffness.



// **SPECIFICATION** Below information is for reference only.

CNC Multi-Guideway Series		Unit	SGX2600	SGX3100	SGX3600
Machining Area	Center Height	mm	1300	1550	1800
	Swing over Bed	mm	2600	3100	3600
	Swing over Cross Slide	mm	2150	2650	3150
	Width of Bed	mm	1830		
	Distance between Centers	mm	3000 ~ 12000		
Headstock	Spindle Bore	mm	180		
	Spindle Nose		A2-20		
	Spindle Speeds	rpm	1 ~ 200		
	Number of Spindle Speeds		4		
Carriage	Rapid Travel Speed (Z / X)	m/min	5 / 5		
	Z-axis Travel, Max	mm	3000 ~ 12000		
	X-axis Travel, Max	mm	1000		
	Z-axis Ball Screw	mm	Ø100		
	X-axis Ball Screw	mm	Ø63		
Tailstock	Quill Diameter	mm	350		
	Quill Taper		MT7		
	Quill Travel	mm	250		
Drives	CNC System		FAGOR 8055i	FANUC 0i-TF	SIEMENS 828D
	Spindle Motor	kW	71	75	74
	Z-axis Servo Motor	kW	6.3	7.0	8.2
	X-axis Servo Motor	kW	6.3	7.0	5.4
			Three Opt. ▶		

// **LOADING CAPACITY**

Between Spindle Center & Tailstock Center

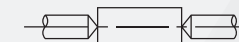

A. Tailstock Quill ø350
33000 KG / 72600 LB

B. Tailstock Quill ø450 (opt.)
40000 KG / 88100 LB

* Z-axis transmission is by racks and dual pinions if DBC ≥ 7m

MODEL SELECTION

Model	Swing over Bed	Swing over Cross Slide	Tailstock Taper	Width of Bed		DBC (m)*
				Main Bedways	W/ Auxiliary Guideway	
SPA600	600	310	MT5	400	---	1.5 ~ 3
SPA670	670	380	MT5	400	---	1.5 ~ 3
SPA770	770	480	MT5	400	---	1.5 ~ 3
SPB670	600	310	MT5	460	---	1.5
						2 ~ 5
SPB770	770	480	MT5	460	---	1.5
						2 ~ 5
SPB840	840	550	MT5	460	---	1.5
						2 ~ 5
SOC960	960	530	MT6	560	660	1.5 ~ 6
SOC1060	1060	630	MT6	560	660	1.5 ~ 6
SOH1200	1190	740	MT7	800	1000	2 ~ 10
SOH1400	1385	940	MT7	800	1000	2 ~ 10
SOH1600	1580	1140	MT7	800	1000	2 ~ 10

*Customized longer DBC is available in SOC, SOH, SGE, SGF and SGX series for specific applications.

Model	Spindle Bore (mm)									
	DBC (m)*	80	104	156	230	260	310	360	410	535
SPA600	1.5 ~ 3	•	•							
SPA670	1.5 ~ 3	•	•							
SPA770	1.5 ~ 3	•	•							
SPB670	1.5		•	•						
	2 ~ 5		•	•	•					
SPB770	1.5		•	•						
	2 ~ 5		•	•	•					
SPB840	1.5		•	•						
	2 ~ 5		•	•	•					
SOC960	1.5 ~ 6			•	•					
SOC1060	1.5 ~ 6			•	•	•	•	•		
SOH1200	2 ~ 10			•	•	•	•	•	•	•
SOH1400	2 ~ 10			•	•	•	•	•	•	•
SOH1600	2 ~ 10			•	•	•	•	•	•	•

▲ Big bores are by customization, please discuss with our sales rep.

MODEL SELECTION

Model	Swing over Bed	Swing over Cross Slide	Tailstock Taper	Width of Bed		DBC (m)*
				Main Bedways	W/ Auxiliary Guideway	
SGF1800	1800	1325	MT7	1345	1575	3 ~ 12
SGF2000	2000	1510	MT7	1345	1575	3 ~ 12
SGF2250	2250	1745	MT7	1345	1575	3 ~ 12
SGF2500	2500	1985	MT7	1345	1575	3 ~ 12
SGE1500S	1500	1000	MT6	1350	1420	3 ~ 15
SGE1500	1500	1000	MT7	1350	1420	3 ~ 15
SGX2600	2600	2150	MT7	1830	1950	3 ~ 12
SGX3100	3100	2650	MT7	1830	1950	3 ~ 12
SGX3600	3600	3150	MT7	1830	1950	3 ~ 12

*Customized longer DBC is available in SOC, SOH, SGE, SGF and SGX series for specific applications.

Model	DBC (m)*	Spindle Bore (mm)										
		80	104	156	180	210	230	260	310	360	410	535
SGF1800	3 ~ 12					•						
SGF2000	3 ~ 12					•						
SGF2250	3 ~ 12					•						
SGF2500	3 ~ 12					•						
SGE1500S	3 ~ 15											
SGE1500	3 ~ 15			•			•					
SGX2600	3 ~ 12				•							
SGX3100	3 ~ 12				•							
SGX3600	3 ~ 12				•							

▲ Big bores are by customization, please discuss with our sales rep.

OPTIONAL ACCESSORY

01 3-Jaw Scroll Chuck



02 4-Jaw Chuck



03 4-Jaw Chuck



04 Face Plate



05 Follow Rest



06 Steady Rest



07 Steady Rest



08 Steady Rest



09 Hydraulic Rear Supporting Stand



10 Boring Device



11 Boring Device



12 Heavy Duty Live Center



13 Hydraulic 4-Way Toolpost (Taiwan)



14 Hydraulic 8-Station Turret (Taiwan)

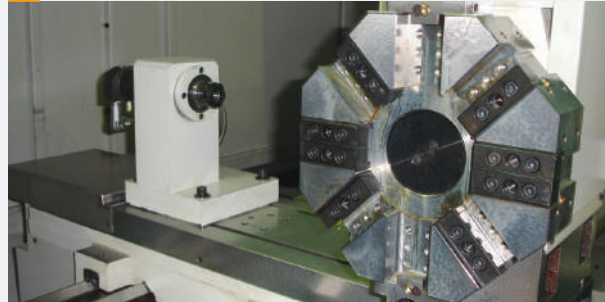

▼ BUILDING GREAT MACHINES MAKES...

MYDAY

15 Enclosed Rear Chuck Guard



16 Fully Enclosed Splash Guard



17 Chip Conveyor with Oil Skimmer





T. // 886-4-2335-1313

F. // 886-4-2335-2259

E. // sales@mydaymi.com

A. // No. 112-53, Cingguang Rd., Wuri Dist., Taichung City 414, Taiwan

www.mydaycnc.com